

AMPIRE®

BOLD6

German Engineering. Out of the ordinary.



Owner's Manual

English



Before attempting to connect or operate this product, please read the instructions completely.

Precautions

- Pay utmost attention if you install the subwoofers into the driver's compartment.
- Use only on minimum 4 ohm stable devices.
- Make the correct connections.
- Do not damage pipe or wiring when drilling holes.
- Arrange the wiring so it is not crimped or pinched by a sharp metal edge.
- Do not install the subwoofers in locations which might hinder vehicle operations and do not install in locations with any moisture. Use the installation materials provided with the amplifier.
- **Warning!** Subwoofers may produce sound pressure levels that exceed the threshold at which hearing loss may result. They may also impair a driver's ability to hear traffic sounds or emergency vehicles. Practice safe listening when listening to your audio system. This subwoofers are developed for motor vehicle use only.

Environmental Reference

- Old electronic devices don't belong into the bin.
- If you want to dispose this equipment later, remove all cables and send it back to Ampire or bring it to a collection point for old electronic devices.
- You can dispose this device together with your old car, too. You don't have to remove it in this case.
- The packing can be recycled. Dispose the packing in a collecting system planned for it.



Subwoofer Installation

Connect the Speaker outputs of your subwoofer amplifier to the (+) and (-) subwoofer terminals.
Be sure of right connections.
Then fit the speakers like shown.

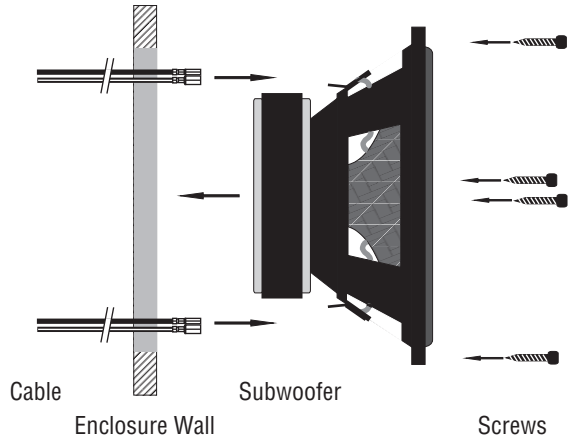

Recommended Enclosures

Sealed enclosure incl. Chassis

10,0 liter
F3: 66Hz
SPL-max: 110dB @ 70Hz

Bassreflex enclosure incl. Chassis and port

11,4 liter, port: 5 x 20cm
F3: 42Hz
SPL-max: 117dB @ 56Hz

Dimensions

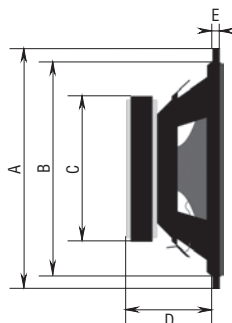

BOLD 6

A	165 mm
B	143 mm
C	126 mm
D	80 mm
E	4 mm

Technical Specifications

Fs / Hz	40,28
VAS / L	10,89
Qts	0,45
Qes	0,49
Qms	5,60
Re /	3,3 + 3,3
Z /	4 + 4
SPL / dB	83,5
Mmd / gr.	31,83
Xmax / mm	8
Sd / cm²	126,7
Vd / cm³	101,4
D / mm	127,0
Pe / Watt	125 / 250

Since its founding in 1987 Ampire Electronics has only one goal, to provide the best possible Autoalarm-, Autohifi- and Multimedia products, which are available on the international market.

All manufacturing facilities and suppliers are certified according to ISO 9001 and QS-9000. Ampire quality products are sold worldwide.

An Ampire customer service is available in many countries.
For more information about distributors in your territory please call: + 49-2181-81955-0.

We are focused on future oriented development of user friendly products.
The outstanding high quality standards, functionalities and designs of our products are unique in the market. "German Development" is taken literally in AMPIRE.

Langwadener Straße 60
D-41516 Grevenbroich
Email: info@ampire.de

Technical Support:
Phone: 02181-81955-0
Email: support@ampire.de

www.ampire.de